

LC4X4 – EXTREME-DUTY 5,500KG GVM UPGRADE

TAC4-EX (EXTREME-DUTY 5500 KG)

DESCRIPTION				GVM OPTIONS		SUSPENSION CONFIGURATION OPTIONS						
BASE CHASSIS	DRIVE	MODEL COMPATIBILITY	MAX CONSTANT GVM	MAX CONSTANT PAYLOAD	TCHC AXLE	COIL FRONT	LEAF REAR	REAR COIL	IFS	IRS	VECTOR	
TAC4-EX	EXTREME-DUTY	4X4	LC76 / LC78 / LC79	5 500 Kg	3 300 Kg	STANDARD	OPTIONAL	OPTIONAL	OPTIONAL	OPTIONAL	OPTIONAL	STANDARD

The Extreme-Duty 5500Kg GVM offering ensures a consistent payload of 3300Kg is managed with stability and improved on and off-road handling and prevents the rear of the vehicle from squatting.

Basic Components List:

- Front weight-corrected coils
- Rear weight-corrected leaf spring packs
- Heavy-duty suspension bushes and hardware
- Heavy-duty shock absorbers
- Heavy-duty steering damper
- Castor correction brackets
- Front axle shock absorber reinforcing brackets
- Brake line relocation brackets
- Braided brake lines (front and rear)
- Brake lines, ABS anti-pull cables
- Front and rear extended axle breather tubes
- Track-corrected rear axle
- Rear disc brake upgrade
- Driveline handbrake system
- Hydraulic brake booster replacement
- Front heavy-duty anti-sway bar
- Rear heavy-duty anti-sway bar
- Chassis augmentation
- Front axle exoskeleton reinforcement
- Replacement brake pads (high thermal capacity)
- Front chassis augmentation
- Reinforced front and rear recovery points

LC4X4 – EXTREME-DUTY 5,500KG GVM UPGRADE



Chassis Augmentation:

- Main chassis frame augmentation
- Front chassis frame augmentation
- Reinforced front and rear recovery points

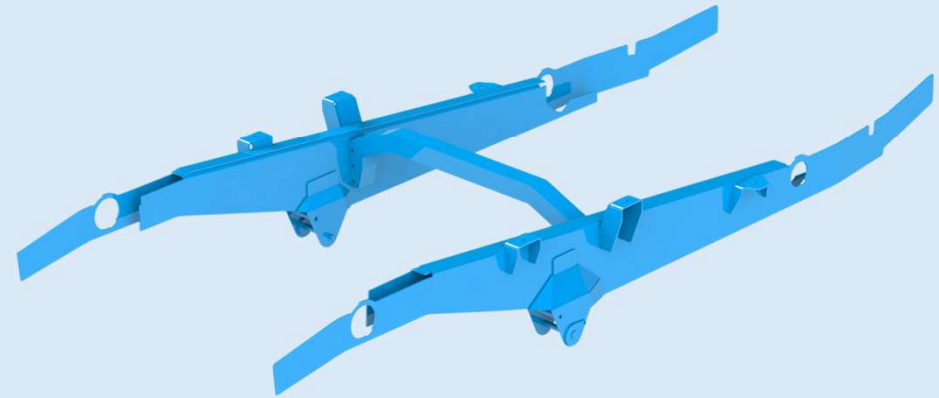

LC4X4 – EXTREME-DUTY 5,500KG GVM UPGRADE



Engineered High Capacity Suspension:

- Front weight-corrected coils
- Rear weight-corrected leaf spring packs
- Heavy-duty suspension bushes and hardware
- Heavy-duty shock absorbers
- Heavy-duty steering damper
- Castor correction brackets
- Reinforced front axle shock absorber mount brackets
- Front heavy-duty anti-sway bar
- Rear heavy-duty anti-sway bar

LC4X4 – EXTREME-DUTY 5,500KG GVM UPGRADE



Drivetrain Upgrade:

- Front and rear extended axle breather tubes
- Track-corrected heavy-duty rear axle
- Front axle exoskeleton reinforcement
- Driveline handbrake system
- Extreme-duty drive shafts



Braking System Enhancement:

- Brake line relocation brackets
- Brake lines, ABS anti-pull cables
- Rear disc brake upgrade
- Hydraulic brake booster replacement
- Braided brake lines (front and rear)
- High thermal capacity brake pads

LC4X4 – EXTREME-DUTY 5,500KG GVM UPGRADE



Tactical Mobility Upgrades:

- Operational cargo modules
- Reinforced tactical bumpers
- Extended-range 185L fuel tank
- Heavy-Duty dual spare wheel carrier

